

Chromatec MADI-xx

MADI Converter & Router
Networkable Multi-channel Audio Monitoring System



- * Up to 192 channels
- * Flexible A to D, D to A & D to D Conversion
- * Programmable Alarms
- * Remote Control + Monitoring over IP



MICHAEL STEVENS & PARTNERS LTD

INVICTA WORKS ELLIOTT ROAD, BROMLEY, KENT, BR2 9NT UK

TEL: +44 (0)20 8460 7299 Fax: +44 (0)20 8460 0499

E-MAIL: SALES@MICHAEL-STEVENSON.COM WEB: WWW.CHROMATEC.COM WEB: WWW.MICHAEL-STEVENSON.COM

Introduction

In response to the growing use of MADI as an interconnection standard, the Chromatec MADI-xx is equipped with MADI connectivity and routing; plus signal conversion, 128 channels of industry standard metering and full alarms functionality.

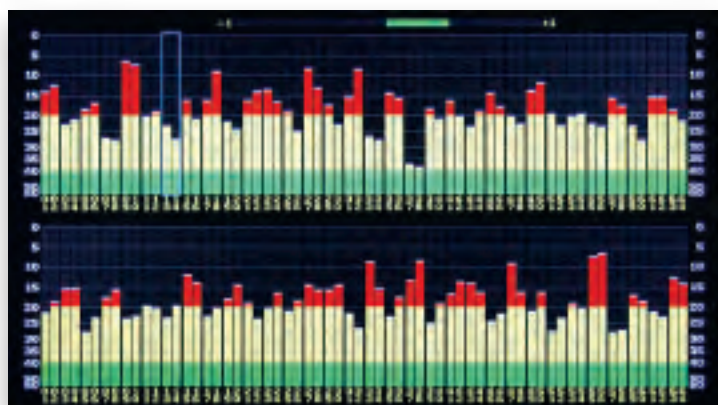

128 Channels

MADI-xx has been designed for use in live sound, theatres, concert halls, radio and TV, and is entirely suitable for both permanent and temporary installations.

At the heart of the unit is a 128 x 128 MADI routing matrix. This enables selection of any input channel to any output. Additionally, to support analogue or AES/EBU signals, there are optional I/O cards. Each card supports 32 channels of inputs or outputs, up to a maximum of 64 inputs or

64 outputs per frame. This gives a total matrix size of 192 x 128 (or 128 x 192).

There is considerable flexibility both in how the MADI-xx may be configured and the range of solutions that it provides.

The MADI-xx can convert any of the incoming or outgoing audio into multi-channel level data (in accordance with established metering standards). This can be displayed locally through its own DVI-I graphical output, or sent over a TCP/IP network to other devices that can render audio meter bargraphs and alarm status information to screen.

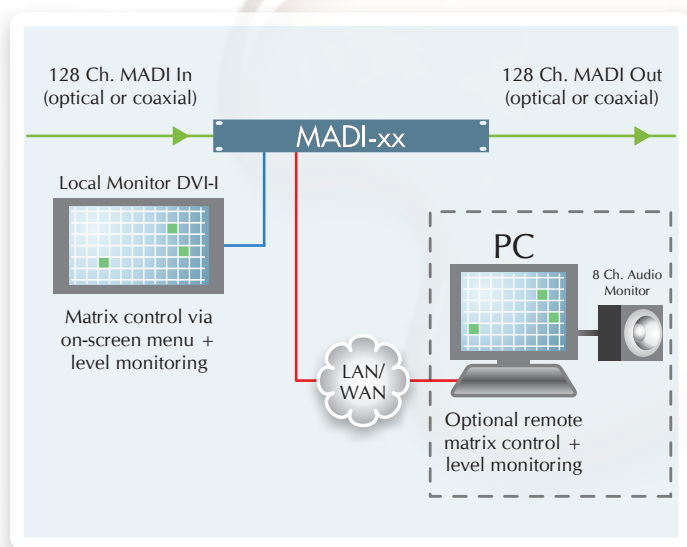
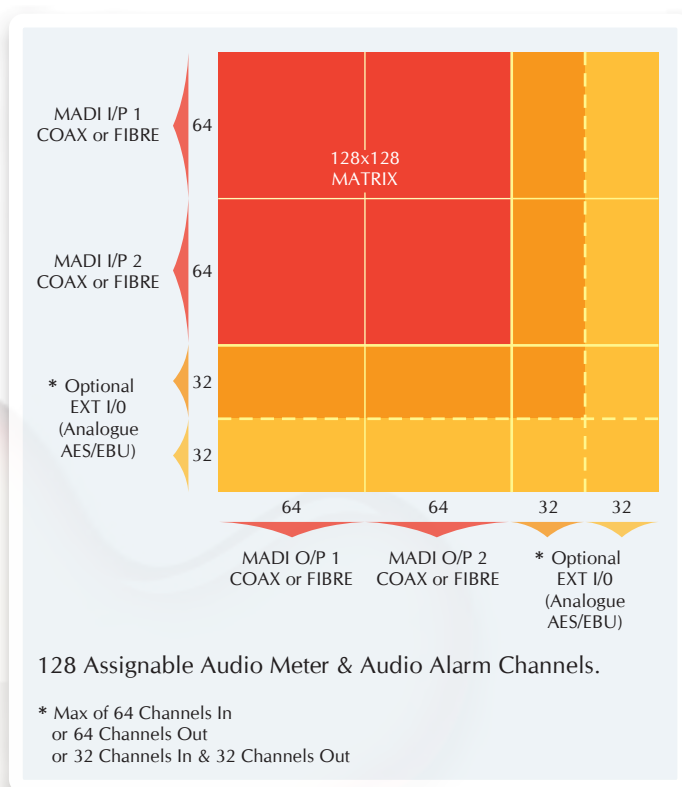

The local graphical output also allows for the configuration of the unit via an on-screen menu.

Up to four pairs of audio channels can be selected for monitoring. These can be streamed over the TCP/IP network and are available via an optional monitor output card in both analogue and AES/EBU formats.

A to D, D to A and D to D signal conversion

In any audio system where there is a range of analogue and digital signal formats, there is the inevitable requirement to convert between formats.

The MADI-xx allows any of its MADI, analogue or AES/EBU inputs to be converted to any of these three formats.

This allows the system to be configured to suit numerous applications.

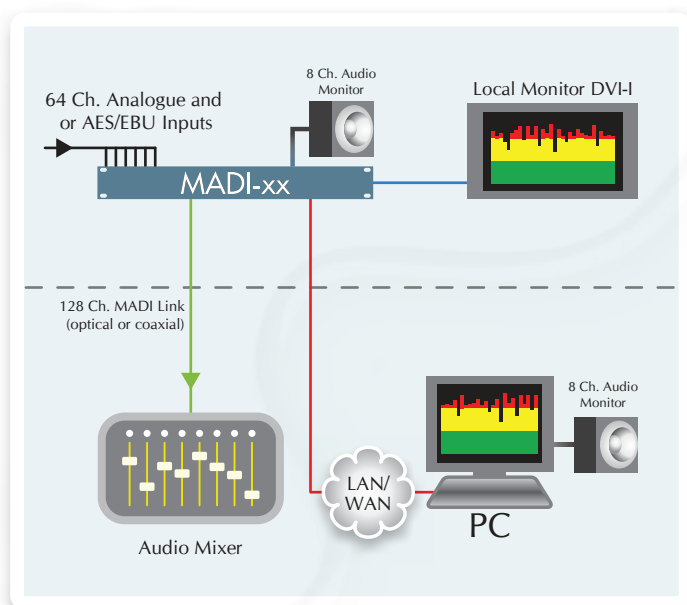

Signal Transmission

Programme production increasingly requires a contribution from people in more than one place. By wrapping up to 128 sources** into two MADI streams, the MADI-xx enables quick and easy transmission of those sources to another site. Another MADI-xx at the destination converts the

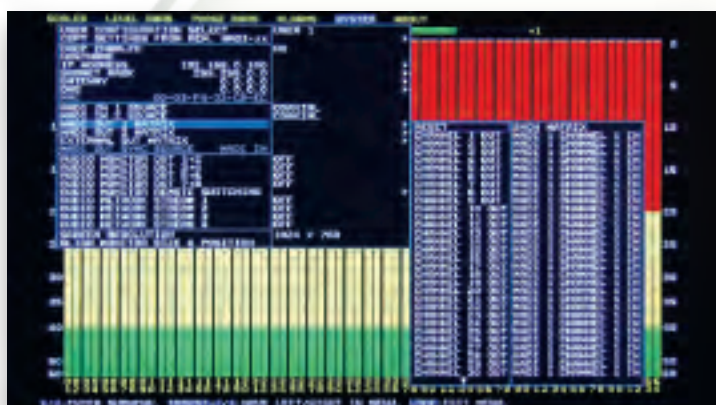
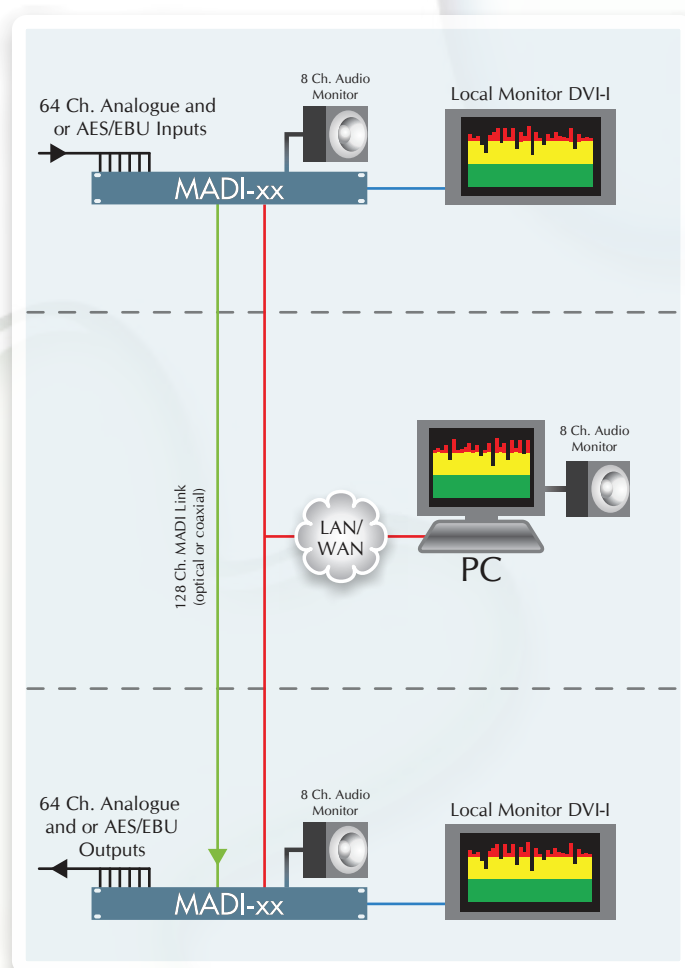

Matrix Menu

MADI stream into the required signal types at that location.

The MADI stream can be transmitted via coaxial or fibre cable.

** Can be various signal formats. See *Technical Configuration and Options* section.

Break-in / Break-out of MADI streams

While MADI is an efficient means of transporting many audio channels and its digital format ensures that high quality is maintained, sometimes it's necessary to gain access to individual audio channels within the MADI stream.

The MADI-xx provides that opportunity. It's an easy matter to break-out up to 16 pairs (analogue or AES/EBU), to carry out any external processing and to break back in again. It couldn't be simpler!

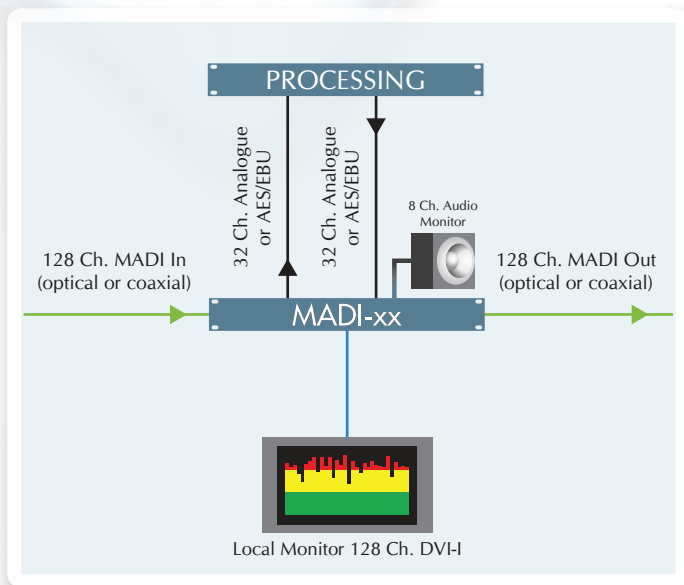

Remote monitoring

By their design requirements, sound control rooms are usually built for high quality visual and audible monitoring. But there is an increasing need for personnel in other locations to access and monitor those same audio signals.

MADI-xx provides an efficient way to check levels and monitor signals contained in a MADI stream. If the programme source is a mixing console which already has a MADI output, one MADI-xx at the remote location is all that is required.

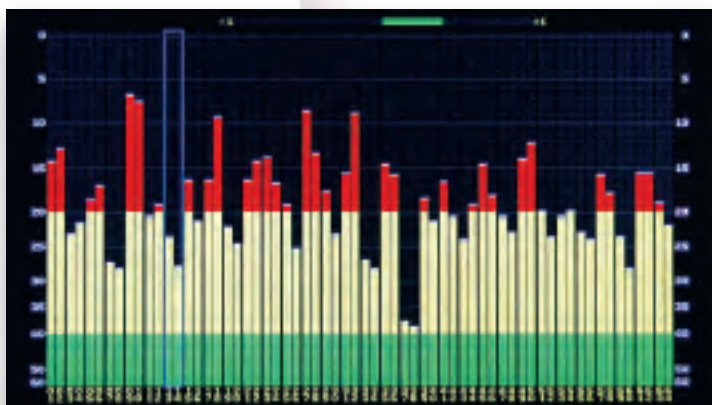
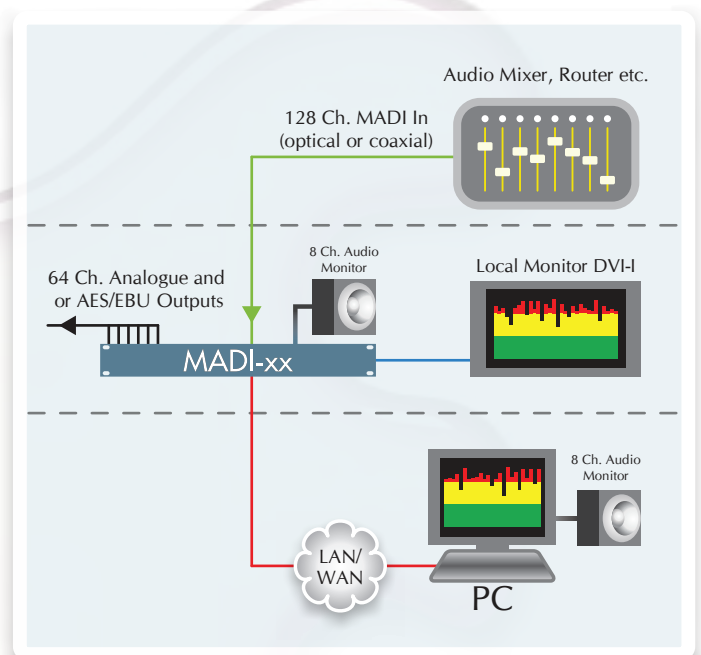

64 channel Digital PPM

If the mixing console does not have MADI output, an additional MADI-xx will provide a suitable MADI feed to the remote destination.

Configuration

The MADI-xx has 2 x MADI inputs/outputs each having duplicated optical and coaxial connectors. Each MADI stream is capable of containing up to 64 audio channels. A maximum of two external audio cards, each 32ch, may optionally be fitted providing an additional 64 inputs or outputs. These may be analogue or AES/EBU or any combination of input and output cards. The total number of input channels can therefore be 192 with 128 outputs, 128 with 192 outputs, or the unit may also be configured 160 inputs, 160 outputs!

The electronics are housed in a 1U case with a removable front panel allowing cards to be “hot swapped” while the unit is in operation. For part filled frames, additional cards can be fitted to empty slots via the front panel. Main processor, LAN and audio monitor cards are also accessible from the front.

All firmware is stored in field programmable FLASH memory for easy updating.

Options

- Monitor output card: Provides local monitoring of up to four audio pairs in both analogue and AES/EBU formats.
- Input cards: Two card types are available, each handles 32 channels (16 pairs) of analogue or AES/EBU.
- Output cards: Two card types are available, each handles 32 channels (16 pairs) of analogue or AES/EBU.

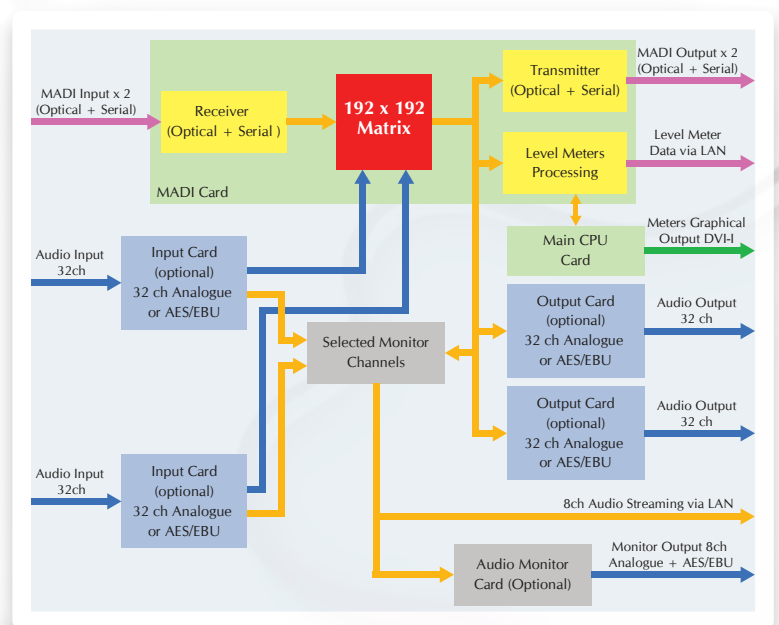

- Up to two input/output cards may be fitted per frame enabling a total of 64 channels in or out or 32 channels in + out, depending on requirements.
- SOFT-xx Windows(R) application: Provides multiple frame integration and system administration. Multi-channel audio metering and alarm status may be displayed remotely on a PC via the LAN. Other features include storage of all frame settings, automatic configuration scheduling and system logging.
- REMOTE-xx – 1U hard-wired remote control panel which replicates the front panel keys of the MADI-xx, connected via the LAN or RS422.
- ALARMS-xx – 1U hard-wired remote alarms status and re-set panel with LEDs to display each channel’s alarm status. There is an audible alarm and global alarm output port. Each ALARMS-xx has 32 channels which may be assigned to a specific MADI-xx. Four units are therefore required for full 128 channel operation. These are connected via LAN or RS422.

Specification

Input format - standard:	2 x MADI 64 channel, coaxial & optical.
Input format - optional:	Analogue, 32 channels per card, +24dB capability. AES/EBU, balanced / unbalanced, 16 pairs per card Inputs 32/44.1/48/96kHz. All 96kHz AES/EBU input channels are resampled at 48kHz for resynchronisation with the internal clock.
Output format - standard:	2 x MADI 64 channel, coaxial & optical.
Output formats - optional:	Analogue, 32 channels per card, +24dB capability. AES/EBU, balanced / unbalanced, 16 pairs per card Outputs 48kHz 24 bit.
MADI Input / Output Connectors:	Optical type SC & coaxial BNC.
Audio Input / Output Connectors:	4 x 37 pole, Sub-D for analogue & AES-EBU.
Reference Input:	AES reference for frame synchronisation.
Data Input / Outputs:	Switchable RS232 or RS422 @ 115Kbps USB-2 working at 6.144MHz. LAN port For all data ports Data out, alarms out/reset, parameter read/set. Audio meter scale/ballistic data will be in dB. 4 pairs streamed/compressed audio monitor outputs.
Audio Monitor Outputs (optional card):	Up to 4 pairs, balanced analogue (max. +20dBu) and AES/EBU 24 bit. All 96kHz AES/EBU sources will be resampled to 48kHz and sent out at 48kHz.
Display Monitor Outputs:	DVI-I (inc. XGA) supporting 4:3 & 16:9 aspect ratios. Graphical interface firmware.
Size:	484 (W) x 355 (D) x 1U (overall)
Weight:	6.75Kgs (full frame).
Power Requirements:	100-250VAC, 47-63Hz, 50W.

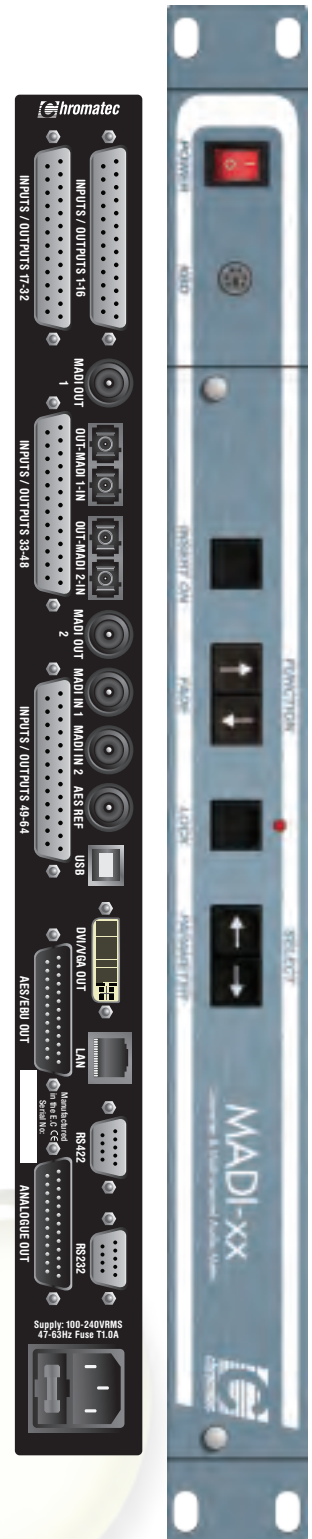

www.chromatec.com

Features and specifications subject to change without notice.